

100 Series Assembly Instructions

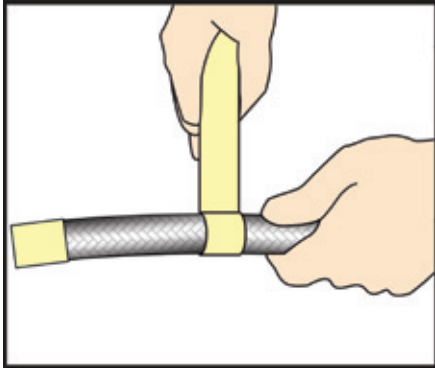

1 Wrap masking or electrical tape around stainless braided hose to stop fraying. Then cut hose square with a fine cut off wheel or fine hacksaw.

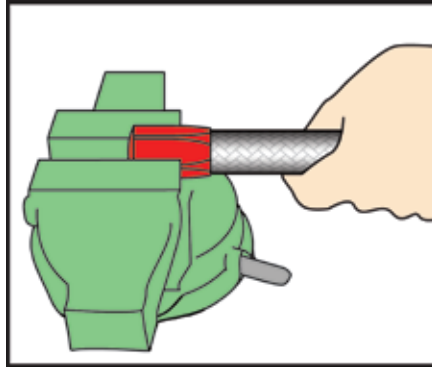

2 Holding the socket nut in the fitting soft jaws, remove the tape and proceed to push it into the nut while twisting the hose. This is a tight fit due to the design of the fitting. We recommend the use of the Proflow installations tool to make this job easier.

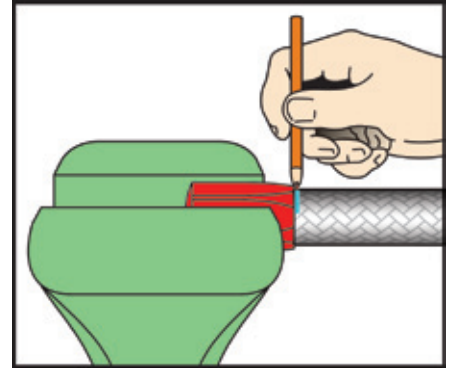

3 Once the hose is all the way in, use a maker to mark a line where the socket nut finishes.

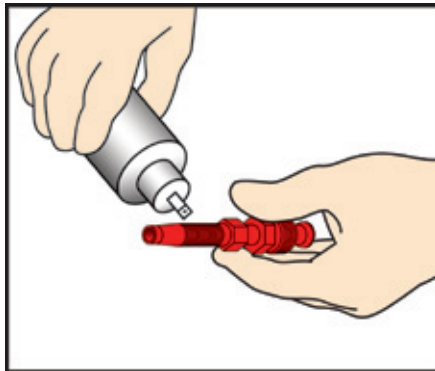

4 lubricate the inside of the hose and the outside of nipple including the threads.

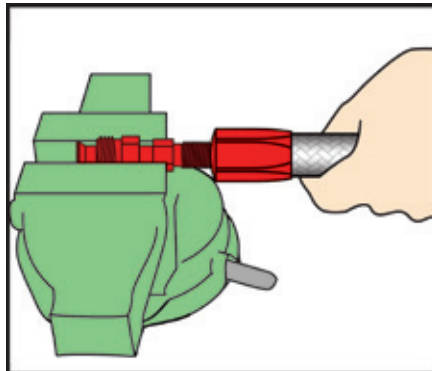

5 Push the socket nut on to the nipple thread.

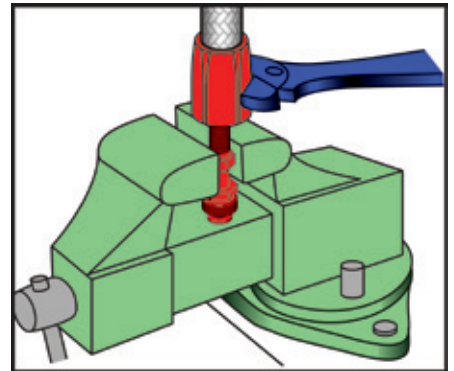

6 Proceed to tighten until the fitting has gap no smaller than your nail . Make sure the mark on the hose has not moved back from the end of the socket nut. The hose is now ready to use. Use compressed air to remove any foreign objects from the lines.