

## 200 Series & AC100 Series Assembly Instructions

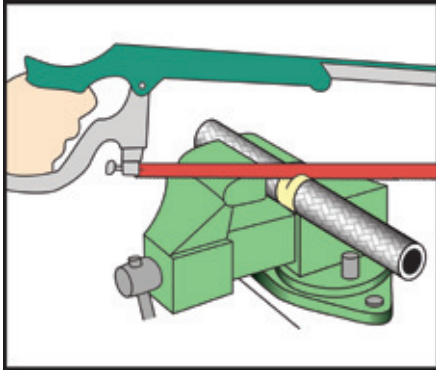

1 Wrap masking or electrical tape around stainless braided hose to stop fraying. Then cut hose square with a fine cut off wheel or fine hacksaw. Clean the end of the Teflon and any stray braid.

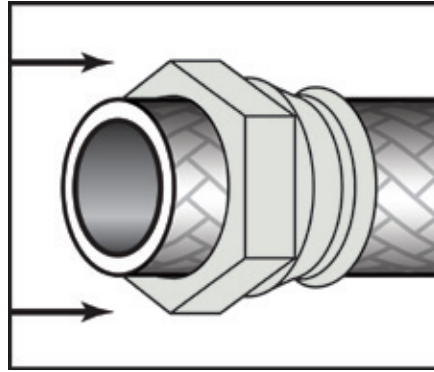

2 Place the socket nut over the Teflon hose and move down 150 mm.

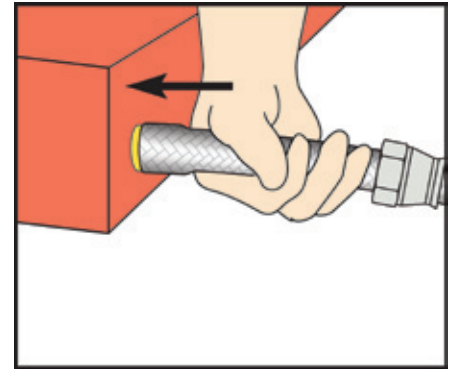

3 Push the olive onto the Teflon using an olive tool or using the bench face allowing the braid to move over the top of the olive.

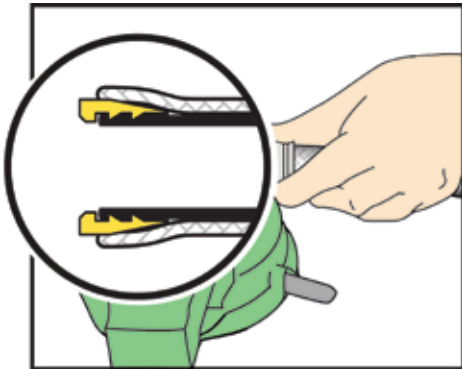

4 Check that the olive has seated correctly.

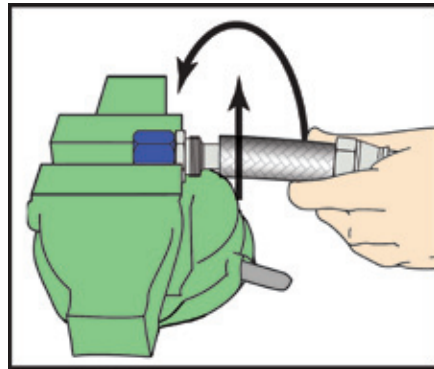

5 Use a small amount of lubricant and push the olive over the shank of the fitting. Twisting and pushing until the thread starts on the fitting.

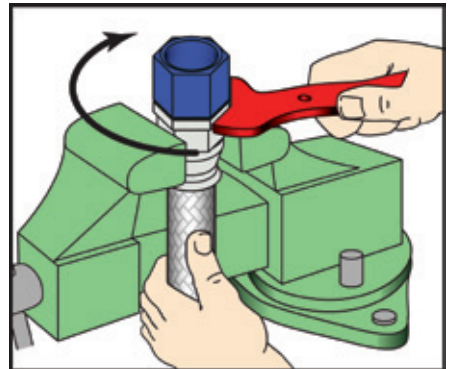

6 Proceed to tighten until the fitting has gap no smaller than your nail. The hose is now ready to use. Use compressed air to remove any foreign objects from the lines. When re using these fittings, it will require a new olive. These are available as a spare part.